

# Total Harmonic Distortion Reduction of Brushless DC Motor using SVPWM Commutation Topology

Santanu Mondal<sup>1</sup> and Madhurima Chattopadhyay<sup>2</sup>

<sup>1</sup>Department of Electronics and Instrumentation Engineering, Techno India, Salt Lake, India

<sup>2</sup>Department of Applied Electronics and Instrumentation Engineering, Heritage Institute of Technology, India

## Abstract

*This article demonstrates the reduction of harmonic distortion using field oriented commutation (FOC) technique in sensorless BLDC motor. The conventional sensorless drive techniques in brushless DC (BLDC) motor involve a six MOSFET based six-step inverter that is fed with Pulse Width Modulated (PWM) commutation signals. The aforesaid method uses trapezoidal back EMF for the detection of rotor position. The trapezoidal or six step commutation method is the simplest scheme available for both speed control and drives in sensorless Brushless DC motor, however such technique fails to perform at lower rotational speeds (rpm) and exhibits high torque ripples. To reduce the torque ripples as well as harmonic distortion in conventional BLDC drives, this work presents Space Vector Pulse Width Modulation (SVPWM) technique. This SVPWM based commutation topology changes the switching time in the said six-step inverter by altering the duty cycle of the gate pulse signals in accordance with the average variation of reference voltage vector. Due to this commutation methodology, the output torque ripple of BLDC is smoothing significantly. The design and dynamic performance of the developed SVPWM drive are evaluated in MATLAB/SIMULINK based platform. The performance analysis is estimated in terms of rise time and total harmonic distortion (THD) at low as well as high rpm and finally the rise time of rotor speed is compared with that of trapezoidal based commutation technique (both sensed and sensorless) at different speed which shows satisfactory results over a wide range of speed.*

**Keywords:** BLDC motor; SVPWM; Park transformation; Clark transformation; Total harmonic distortion

## 1. INTRODUCTION

Brushless DC motor has consideration due to the increasing demand in numerous applications such as ventilation, refrigeration, aerospace, electric car, heating, air conditioning, several medical and industrial instruments. Furthermore, BLDC motor does not use brush and commutator so it is inherently non-self-commutating in nature and they require an external commutation circuitry [1-3]. This commutation results in ripples in the torque generated due to the transfer of current from one phase to another. The presence of ripples in the torque of the BLDC motor is also due to design of the motor or power inverter supply resulting in non-ideal current waveforms [4-5]. Torque ripple due to phase current commutation is the main drawback of the BLDC drive system. The effects of ripples in the torque are undesirable due to demanding motion control and precision requirements in machine tool applications [6-8]. Different commutation topologies are found in the literature to minimize the ripples in the torque [9-11]. This paper proposes a low cost method to minimize the pulsating ripples in the torque due to phase commutation using SVPWM. Figure 1 shows a basic block diagram of the SVPWM based BLDC motor, this work assumes the d-q model of the BLDC motor and uses rotor angle as position feedback, and this method creates more reference points than 3 reference points which is standard for other commutation techniques. This is helpful to regulate the oscillation of stator current, limiting torque ripple in the process. The SVPWM method proposed here does not create harsh current transitions through the motor coils, because the current and phase voltages are sinusoidal in nature. The SPWM method provides precise and smooth control of BLDC motor which traditional commutation is unable to achieve [12].

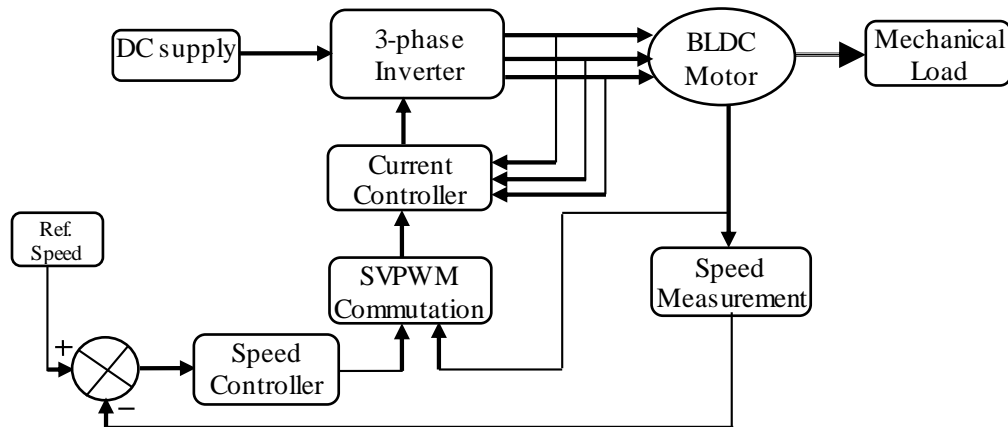

Figure 1. Basic block diagram of the SVPWM based BLDC motor

The paper agreement is as follows. The first section familiarizes the work followed discussion on the circuit operation and modeling of the BLDC drive in Section 2. The proposed SVPWM commutation technique is presented in Section 3. Subsequently, the MATLAB/SIMULINK model of the designed SVPWM commutation technique based BLDC drive is given in Section 4. Experiment results and discussion are presented in Section 5 and section 6 concludes with some final remarks.

## 2. MATHEMATICAL MODELING OF BLDC MOTOR DRIVE

The benefit of the brushless DC motor in direct quadrature (d-q) coordinate model is that the rotor angular position  $\theta$  is not directly involved in the motor dynamics equations. As a consequence, the dynamic analysis and control using (d-q) coordinate model are significantly simpler than using phase model (a-b-c) coordinates. To transform the phase equation of the BLDC model to direct quadrature coordinates necessary for space vector analysis Clark and Park transform is implemented. Clark inverse and Park inverse is used to revert the direct quadrature coordinates to the phase model equation of the BLDC model [13-14].

### 2.1 Modeling of Brushless DC Motor

BLDC motor consists of a permanent magnet rotor which rotates, encircled by three equally spaced windings, which are fixed (the stator). The current flow in each winding produces a magnetic field vector. The three-phase motor current feedback is transformed into a space vector in the d-q frame and is separated into two parts (the d and q component) which are controlled separately so that the controller can produce any current vector in the d-q frame. The BLDC model used in the SPWM technique is designed in the d-q model. Here the BLDC is fed by a sinusoidal signal and therefore the harmonics can be analyzed in the d-q model [15-16].

### 2.2 Clark Transformation

The Clark transformation is used to convert three phase  $abc$  reference frame to stationary  $\alpha\beta$  reference frame, and inverse Clark transformation is used to convert time domain  $\alpha\beta$  to  $abc$  axis. Figure 2 and 3 shows the Simulink model of Clark and inverse Clark transformation respectively.  $V_a$ ,  $V_b$  and  $V_c$  are three phase stator voltages.

$$\begin{bmatrix} V_\alpha \\ V_\beta \end{bmatrix} = \sqrt{\frac{2}{3}} \begin{bmatrix} 1 & -1/2 & -1/2 \\ 0 & \sqrt{3}/2 & -\sqrt{3}/2 \end{bmatrix} \begin{bmatrix} V_a \\ V_b \\ V_c \end{bmatrix} \quad (1)$$

$$\begin{bmatrix} V_a \\ V_b \\ V_c \end{bmatrix} = \sqrt{\frac{2}{3}} \begin{bmatrix} 1 & 0 \\ -\frac{1}{2} & \frac{\sqrt{3}}{2} \\ -\frac{1}{2} & -\frac{\sqrt{3}}{2} \end{bmatrix} \begin{bmatrix} V_\alpha \\ V_\beta \end{bmatrix} \quad (2)$$

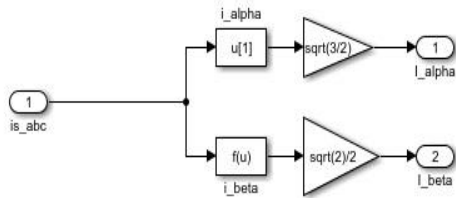

Figure 2. Simulation model of Clark transform

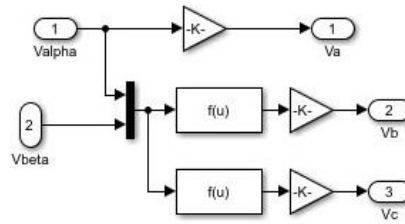

Figure 3. Simulation model of inverse Clark transform

### 2.3 Park transformation

The Park transform is used to convert the fixed reference frame  $(\alpha, \beta)$  to rotating reference frame  $(d, q)$ , and inverse Park transform is used to convert rotating reference frame  $(d, q)$  to fixed reference frame  $(\alpha, \beta)$ . Figure 4 and 5 shows the Simulink model of park and inverse park transformation correspondingly.

$$\begin{bmatrix} V_d \\ V_q \end{bmatrix} = \begin{bmatrix} \cos\theta & \sin\theta \\ -\sin\theta & \cos\theta \end{bmatrix} \begin{bmatrix} V_\alpha \\ V_\beta \end{bmatrix} \quad (3)$$

$$\begin{bmatrix} V_d \\ V_q \end{bmatrix} = \frac{2}{3} \begin{bmatrix} \cos\theta & \cos(\theta - \gamma) & \cos(\theta + \gamma) \\ -\sin\theta & -\sin(\theta - \gamma) & -\sin(\theta + \gamma) \end{bmatrix} \begin{bmatrix} V_a \\ V_b \\ V_c \end{bmatrix} \quad (4)$$

Where,  $\gamma$  is  $2*\pi/3$  and  $\theta$  is rotor angle or angle between alpha-beta axis and d-q axis. The BLDC control block is given by q-axis control, d-axis control and torque speed control.

The d-axis control block is given by Eq.5

$$\frac{1}{sL_d} = V_q - (i_q * \omega_e)L_q - i_dR \quad (5)$$

Torque speed control block is given by Eq.7 and Eq. 8

$$T_e = i_q Y_{af} + (L_d - L_q)(I_d + I_q) \quad (6)$$

$$T_e - T_m - \left(\frac{2B}{P}\right) * \omega_e = \frac{P\theta}{Js} \quad (7)$$

Where,  $L_q$  and  $L_d$  are inductance,  $R$  is stator resistance,  $Y_{af}$  is rotor flux constant,  $J$  is moment of inertia,  $B$  is friction viscous gain,  $P$  is number of poles.

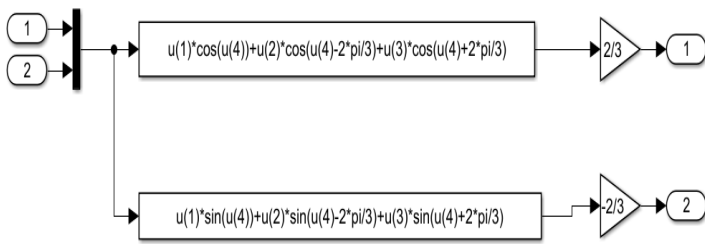

Figure 4. Simulation model of Park transform

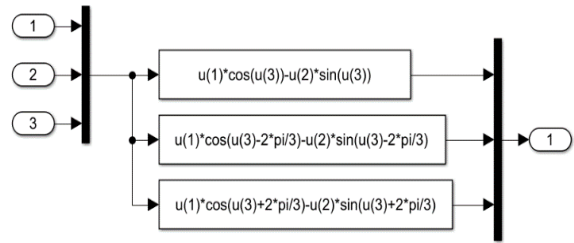

Figure 5. Simulation model of inverse park transform

### 3. SVPWM COMMUTATION TECHNIQUE

The space vector pulse width modulation concept is derived from the rotating field of induction motor. This is used for modulating the inverter output voltage. In this modulation technique, the three-phase quantities can be transformed to their equivalent two-phase quantity either in synchronously rotating frame or stationary frame [17-18]. From these two-phase components, the reference vector magnitude can be found and used for modulating the inverter output. This commutation technique computes near switching vector sequence to the reference vector and the corresponding switching state determined by comparison and simple addition. This technique is defined in accordance with the spatial position of the windings applied to the voltage. Three-phase stator voltage that applied on the three-phase winding can define three voltage space vector. The connection is such that the addition of the three phase components is 0, i.e,  $V_a + V_b + V_c = 0$  or  $i_a + i_b + i_c = 0$ . There are  $2^3 = 8$  kinds of switch status for the entire three-phase inverter. Alternatively using these eight states, PWM waveform will be generated such that the average phase will be sinusoidal. These 8 states are: 000, 001, 010, 011, 100, 101, 110, 111. 000 and 111 are considered zero inverter states as the inverter's only lower arms and only upper arms are conducting respectively, this two inverter states making zero output voltage are known as zero switching states.

The SVPWM consists of few steps. First determine the switching vectors ( $V_d, V_q, V_{ref}$  and angle  $\alpha$ ). Second, computations of time duration  $T_1, T_2, T_0$  and third, determine the switching time of each transistor ( $S_1$  to  $S_6$ ). The objective of space vector PWM technique is to approximate the reference voltage vector  $V_{ref}$  using the eight switching patterns. One simple method of approximation is to generate the average output of the inverter in a small period,  $T$  to be the same as that of  $V_{ref}$  in the same period.

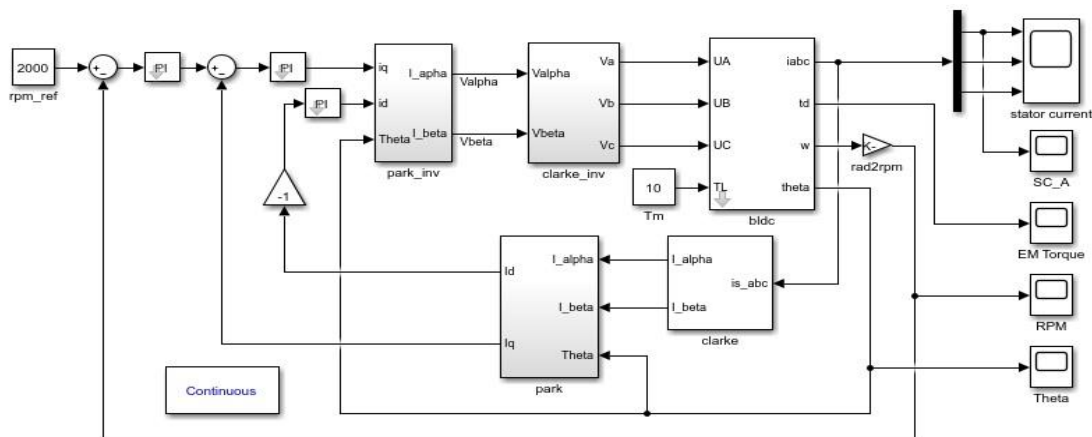

Figure 6. MATLAB/SIMULINK model of the proposed system

#### 4. MATLAB/SIMULINK MODEL OF BLDC MOTOR USING SVPWM

The system consists of speed,  $d$  and  $q$  axes current PI regulators, Park and Clarke transformations, inverse Park transformation, space vector generation, speed calculation and PWM generator modules. An incoming speed command goes into a speed PI regulator which outputs  $q$  axis reference current. The  $d$  axis current reference is set to zero. These current references and their corresponding feedbacks are DC quantities for the PI regulators to track easily [19-20]. The outputs of the current PI regulators generate stator  $d$ - $q$  axes voltage references which are also in DC quantities. The space vector pulse width modulation converts the stationary reference from voltage references into  $abc$  frame-based duty cycle equivalences. To obtain the  $d$ - $q$  axes current feedbacks in DC quantities, first  $a$ - and  $b$ -axes AC currents are transformed into stationary values using Clarke transformation and then the stationary current values acquired from Clarke transformation are set up as inputs to the Park transformation along with the rotor position feedback signal to generate the equivalent DC feedback quantities in  $d$ - $q$  reference frame. Park transformation is used to transform the stator quantities of a BLDC onto a  $d$ - $q$  reference frame that is fixed to the rotor, with the positive  $d$  axis aligned with the magnetic axis of the rotor. It is possible to separate the motor complex space vectors into stationary real and imaginary parts with the Clarke transformation. By using the Clarke transformation in stator currents is transformed from three-phase to two-phase quadrature equivalent values as inputs to the Park transformation.

#### 5. RESULTS AND DISCUSSION

The circuit of proposed model implemented in MATLAB/ SIMULINK platform to evaluate the performance of the BLDC motor. The simulation circuit is shown in Figure 6. In this simulation circuit or Simulink model of all semiconductor devices is used. For this model, three different reference speeds are taken as 500 rpm, 1000 rpm and 2000 rpm with 10 Nm constant load Torque. This paper shows the simulation study of the different rpm by analyzing the output waveforms of the following parameters. Figure 7, 9, 11 and 13 shows the rotor speed, stator back EMF, stator current and electromechanical torque (EM) of the BLDC motor respectively for SVPWM technique. Figure 8, 10, 12 and 14 show FFT analysis of rotor speed, stator back EMF, stator current and Electromechanical Torque of the BLDC motor respectively also shows the corresponding total harmonic distortion (THD). It can be seen that the results are shown a good agreement with simulation outcomes. Specifications of the proposed model are given in Table 2.

To analyze the performance of the proposed system and evaluate rise time for different speed. The evaluated values are illustrated in Table 1. For 500 rpm the rise time of rotor speed waveform of the proposed SVPWM system (2.77 ms) gives much better output than back EMF method (4.43 ms) and standard sensed method (17.608 ms). For 1000 rpm the rise time of rotor speed waveform of the proposed SVPWM system (6.0 ms) gives better output than back EMF (15.743 ms) and standard sensed method (9.587 ms). Whereas the 2000 rpm the rise time of speed waveform of the standard sensed method (13.573 ms) much better than the proposed SVPWM method (25.99 ms) and back EMF method (22.825 ms).

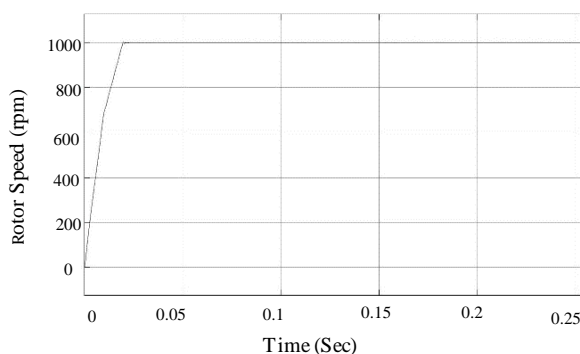

Figure 7. Rotor speed waveform for reference speed of 1000 rpm

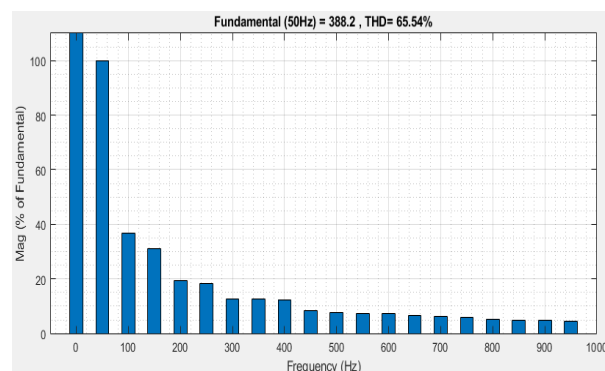

Figure 8. FFT analysis of rotor speed using reference speed of 1000 rpm

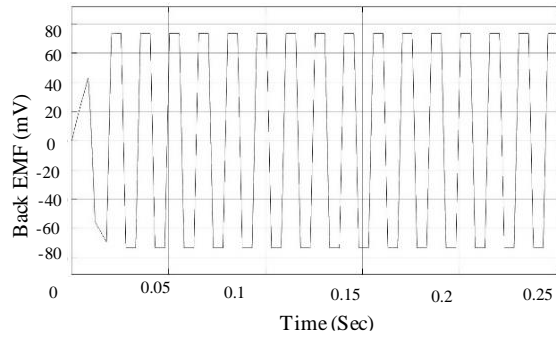

Figure 9. Stator back EMF waveform for reference speed of 1000 rpm

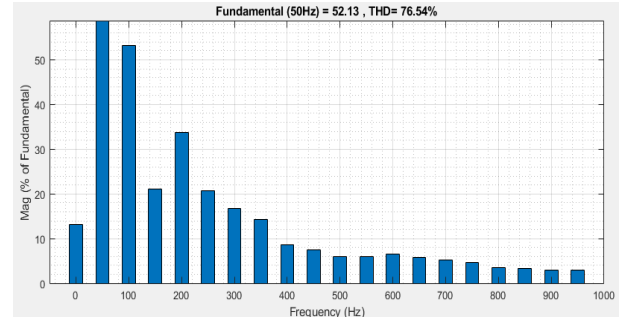

Figure 10. FFT analysis of stator back EMF using reference speed of 1000 rpm

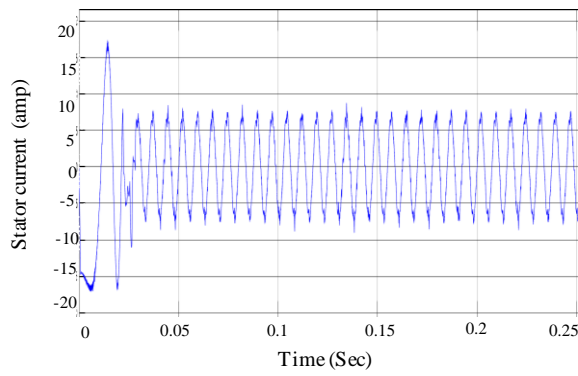

Figure 11. Stator current waveform for reference speed of 1000 rpm

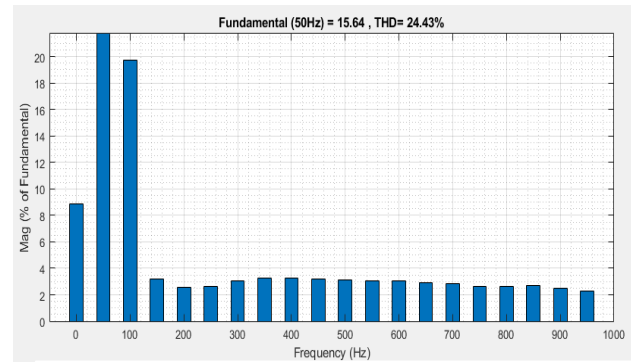

Figure 12. FFT analysis of stator current using reference speed of 1000 rpm

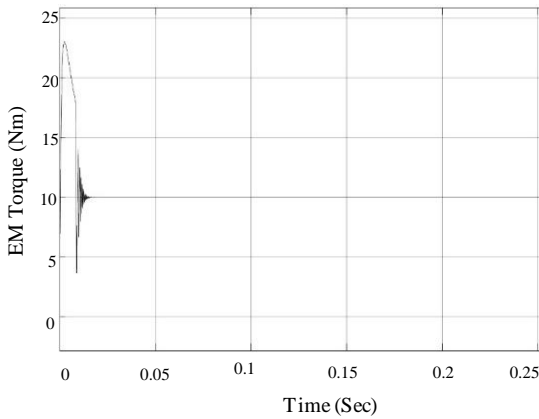

Figure 13. EM Torque waveform for reference speed of 1000 rpm

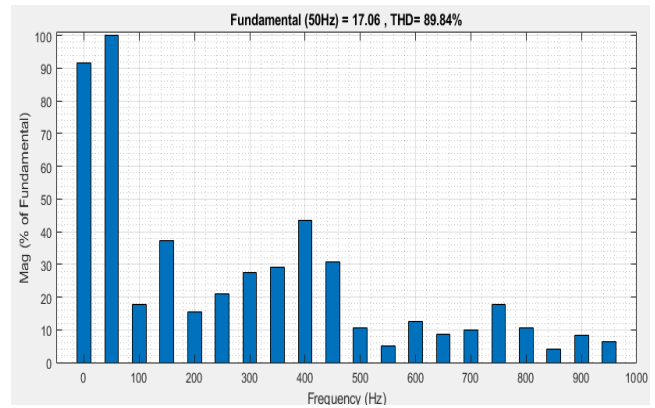

Figure 14. FFT analysis of electromagnetic torque

Table 1. Rise Time Analysis of the Proposed System Calculated from rpm Waveform

Rotor Speed (rpm)	Rise Time(ms)		
	Proposed SVPWM method	Back EMF method	Sensored method
500	2.77	4.43	17.60
1000	6.0	15.74	9.58
2000	25.99	22.82	13.57

Table 2. BLDC motor parameters used for simulation

Motor parameters	Values
Friction Coefficient	$10^{-3}$ Kg/ms
Moment of Inertia	$0.8 \times 10^{-3}$ Kg.m <sup>2</sup>
Inductance	$8.5 \times 10^{-3}$ Henry
No. of poles	4
Resistance per phase	2.8750 ohms
Torque	3 N-m
Torque constant	0.1 N-m/Amp
Back EMF constant	0.175 volts/rad/sec

## 6. CONCLUSION

In this research work, a detailed study on the space vector commutation in a three-phase BLDC motor is presented. The whole study is executed in MATLAB based simulation platform and the parameters like rotor speed, stator current, back emf and electromagnetic torque have been both in time and frequency domain (FFT analysis). In each case of FFT analysis, the total harmonic distortion (THD) at fundamental frequency is calculated and finally compared with common commutation techniques. For the purpose of comparison, we consider three reference speeds of rotor viz., 500 rpm, 1000 rpm and 2000 rpm. The SVPWM technique compared with both back EMF and sensed drive of BLDC motor is much advantageous due to minimal THD value. In addition, the rise/response time of the motor also improves by introducing SVPWM method as shown in Table 1 in precise controlling applications, SVPWM can function more accurately with less THD and produces a smooth dynamic response.

## REFERENCES

- [1]. J. D. Viaene, F. Verbelen, S. Derammelaere and K. Stockman, "Energy-efficient sensorless load angle control of a BLDC motor using sinusoidal currents", *IET Electric Power Applications*, 12(9), 1378 – 1389, 2018.
- [2]. S. Mondal, A. Mitra, & M. Chattopadhyay, "Mathematical modeling and simulation of Brushless DC motor with ideal Back EMF for a precision speed control", *IEEE International Conference on Electrical, Computer and Communication Technologies (ICECCT)*, Coimbatore, India, March 5-7, 2015.
- [3]. W. Jiang, P. Wang and Y. Liao, "Multimode Current Hysteresis Control for Brushless DC Motor in Motor and Generator State With Commutation Torque Ripple Reduction", *IEEE Transactions on Industrial Electronics*, 65(4), 2975 – 2985, 2018.
- [4]. S. Mondal, A. Nandi, I. Mallick, C. Ghosh, and A. Giri, "Performance Evaluation of Brushless DC Motor Drive for Three Different Types of MOSFET Based DC-DC Converters", *Devices for Integrated Circuit (DevIC)*, *IEEE International Conference, Kalyani, India, March 23-24, 2017*.
- [5]. Y. Cao, T. Shi, Y. Liu, and Z. Wang, "Commutation Torque produces a smooth dynamic response. Ripple Reduction for Brushless DC Motor With Commutation Time Shortened", *IEEE International Electric Machines and Drives Conference (IEMDC)*, Miami, FL, USA, May 21-24, 2017.
- [6]. K. Basu, J. S. Prasad, and G. Narayanan, "Minimization of Torque Ripple in PWM AC Drives", *IEEE Transactions On Industrial Electronics*, Vol. 56, no. 2, 553 – 558, 2009.
- [7]. C. S. Berendsen, G. C. Champenois, M. Bolopion, "Commutation Strategies for Brushless DC Motors: Influence on Instant Torque", *IEEE Transactions on Power Electronics*, 8(2), 231 – 236, 1993.
- [8]. M. N. Gujjar, and P. Kumar, "Comparative analysis of Field oriented control of BLDC motor using SPWM and SVPWM techniques" *2<sup>nd</sup> IEEE International Conference on Recent Trends in Electronics, Information & Communication Technology (RTEICT)*, Bangalore, India May 19-20, 2017.
- [9]. N. Mohanraja, and R. Sankaran, "Converter Control Strategy for Torque Ripple Minimization in BLDC Motor", *1st International Conference on Power Engineering, Computing and Control, PECCON, chennai, Tamil Nadu, India, March 2-4, 2017*.
- [10]. S. Mondal, A. Majumder, D. Chowdhury, and M. Chattopadhyay, "An efficient power delivering scheme for sensorless drive of Brushless DC motor", *Springer journal, Microsystem Technologies*, 23(1), 1-8, 2018.
- [11]. F. R. Yasien, and R. A. Mahmood, "Design New control System for Brushless DC motor Using SVPWM", *International Journal of Applied Engineering Research*, 13(1), 582-589, 2018.

- [12]. I. Kim, N. Nakazawa, S. Kim, C. Park and C. Yu, "Compensation of torque ripple in high performance BLDC motor drives", *Control engineering practice*, 18(10), 1166-1172, 2010.
- [13]. M. A. Islam, M. B. Hossen, B. Banik and B. C. Ghosh, "Field Oriented Space Vector Pulse Width Modulation Control of Permanent Magnet Brushless DC Motor", *IEEE Region 10 Humanitarian Technology Conference (R10-HTC)*, Dhaka, Bangladesh, December 21-23, 2017.
- [14]. T. Herold, D. Franck, E. Lange and K. Hameyer, "Extension of a D-Q Model of a Permanent Magnet Excited Synchronous Machine by Including Saturation Cross-Coupling and Slotting Effects", *IEEE International Electric Machines & Drives Conference (IEMDC)*, Niagara Falls, ON, Canada, May 15-18, 2011.
- [15]. G. Meng, H. Xiong and H. Li, "Commutation torque ripple reduction in BLDC motor using PWM ON\_PWM mode", *IEEE International Conference on Electrical Machines and Systems*, Tokyo, Japan, November 15-18, 2009.
- [16]. X. Zhang and B. Chen, Influences of PWM mode on the current generated by BEMF of switch-off phase in control system of BLDC motor. *ICEMS'2001, Proceedings of the Fifth International Conference on Electrical Machines and Systems (IEEE Cat. No.01EX501)*, Shenyang, China, August 18-20, 2001.
- [17]. A.V.G. A. Marthanda and G.V. Marutheswar, "A Three Phase Sensor Less Field Oriented Control for BLDC Motor", *International Journal of Advance Engineering and Research Development*, 4(11), 378-384, 2017.
- [18]. T. Jahns, J. B. Kliman and T.W. Neumann, "Interior Permanent-Magnet Synchronous Motors for Adjustable-Speed Drives", *IEEE Transactions on Industry Applications*, 22(4), 738-747, 1986.
- [19]. Y. Xu, Y. Wei, B. Wang, and J. Zou, "A Novel Inverter Topology for Brushless DC Motor Drive to Shorten Commutation Time", *IEEE Transactions On Industrial Electronics*, 63(2), 796 – 807, 2016.
- [20]. O. Lopez, J. Alvarez, J. D. Gandoy and F.D. Freijedo, "Multilevel multiphase space vector PWM algorithm. *IEEE Trans Industrial Electronics*", 55(5), 1933 – 1942, 2008.