

Load Frequency Control of Power System with Renewable Energy Resources

¹M.Sunil Kumar
Department of EEE,
Assistant Professor,
SIR C R Reddy College of
Engineering,
Eluru, A.P, INDIA

²K.Kotaiah Chowdary
Department of EEE,
Assistant Professor,
SIR C R Reddy College of
Engineering,
Eluru, A.P, INDIA

³Dr.V S R Pavan Kumar Neeli
Department of CSE,
Assistant Professor (Senior Level),
Vignan's Foundation for Science
Technology and Research,
Vadlamudi, A.P, INDIA

Abstract—With the emerging technologies the requirement of clean and sustainable energy has become a challenge for the Electrical Engineers in their day to day life. Recent studies suggest that in the next five decades, large portion of the Non Renewable sources accessible will be diminishing. This is the prime concern for attracting the attention for the enhancement in the performance of the renewable energy sources which abundantly exist in the nature. Wind, solar photovoltaic, and solar thermal power systems are emerging renewable technologies that can be developed as a viable option for the future generation of electrical energy. In this paper, we have considered an autonomous hybrid generation system consisting of Wind turbine generator (WG), solar photovoltaic (S-PV), diesel generator(DG), fuel cell(FC), battery energy storage system (BES), solar thermal power system(STPS) and aqua electrolyzers (AE) for simulation studies. In the power system, the frequency deviations are generally due to deviations in load or generation or both. The comparative performance of the controllers installed to alleviate this frequency deviation for different hybrid systems, is carried out using time domain simulations. In practical, tuning of PI and PID controllers is challenging and time consuming. With the introduction of computational intelligence has opened a new pathway for advanced new generation control process. Here, PSO is used as the optimization method to determine the controller gains for the proposed hybrid system. From the results, we can demonstrate the effectiveness of the PSO based controllers in terms of reduced settling time, over shoot, and oscillations. The results are compared with conventional controllers and with the controllers whose gains are tuned by GA.

Keywords—Particle swarm optimization (PSO), Genetic algorithm (GE), PI controller, PID controller, Aqua electrolyzers (Ae), Fuel cell (Fc), Diesel generator (DG), Battery energy storage system (BES), Wind turbine generator (WG), solar photovoltaic (SPV).

I. INTRODUCTION

In the present trends, Electricity plays a vital role in all the aspects of human life. With increasing trends in technology demands more power to be generated through fossil fuel.[1] Thus this increase in power demand leads to ecological imbalance such as increase in carbon emission and global warming. These shifting trends of technology required the necessity for clear, eco-friendly and sustainable energy. [2] Research shifted to the alternative generation sources which are available abundantly in nature such as wind, solar, geo-thermal, tidal, bio-mass, are some of the sustainable green energy sources. Among all the available renewable sources wind and solar are more trending as they have high potential and good efficiency with considerable cost when compared to others. Fuel cell and ultra-capacitors also exhibit similar characteristics and can be considered as green sustainable sources for the future.[3] It is known, that not all the systems can be connected to the grid, some located far from generation stations are to be maintained off grid. Single source systems such as solar photovoltaic, wind generators, micro-hydro systems, diesel generators, or a combination of above systems called as hybrid generation system are used for delivering the load demand. The hybrid system not only delivers load demand but also includes energy storage systems in the form of batteries. Through this system we can deliver both AC and DC power. [4] Thus, by using proper equipment we regulate the overall performance of the system. The design of the controllers includes both conventional and computational intelligence techniques. Numerous optimization methodologies, such as differential evaluation, genetic algorithm, particle swarm optimization, artificial neural network, bat algorithm, are applied to optimize and calculate the gains of the controllers for automatic generation control. The above stated methods were limited to conventional systems but never applied for hybrid systems for optimization of gains for the controllers. In hybrid systems, the controllers generally used are proportional plus integral (PI) which regulates the output power to achieve power equilibrium condition due to abrupt increase in loads and generation. We employ trial and error method described by Ziegler and Nichols to determine the gain values for the conventional PI controller to achieve better balance.[5] This conventional method was not suitable since the gains obtained by this method are suitable for limited operating points. With increase in the number of optimization parameters the conventional controllers does not meet the required robust performance which is certainly not desired. In this paper, the PSO PI, PID controllers used whose gain values are calculated using PSO technique. The PSO is a novel technique which has widespread applications in the system optimizations. The intelligent control strategy provides robust adaptive response with varying parameters like non-linearity, load disturbances. The basics of PSO algorithm are illustrated in[6]. By applying PSO PI, PID controllers to the hybrid system the results obtained are compared with conventional PI, PID, and GA PI, PID controllers respectively. Simulated results show that gains obtained from PSO has improved dynamic performance than the conventional and GA controllers.[7] The PSO controller also had better response for transients during load disturbances.

II. POWER SYSTEM MODEL

The proposed hybrid model block diagram is illustrated in the Fig. 1. The hybrid system is a combined model of wind turbine system, diesel generator, fuel cell (Fc), aqua electrolyser (Ae), solar thermal and solar photovoltaic, and battery energy storage model. [8] The load demand supplied is the summation of all the output powers from wind, solar, fuel cell and battery storage system. As wind is a varying system the fluctuations are absorbed by the aqua electrolyser system producing the hydrogen gas

which is taken as fuel for Fc system. The mathematical modeling of the hybrid system involves first order transfer functions of as shown in this section.

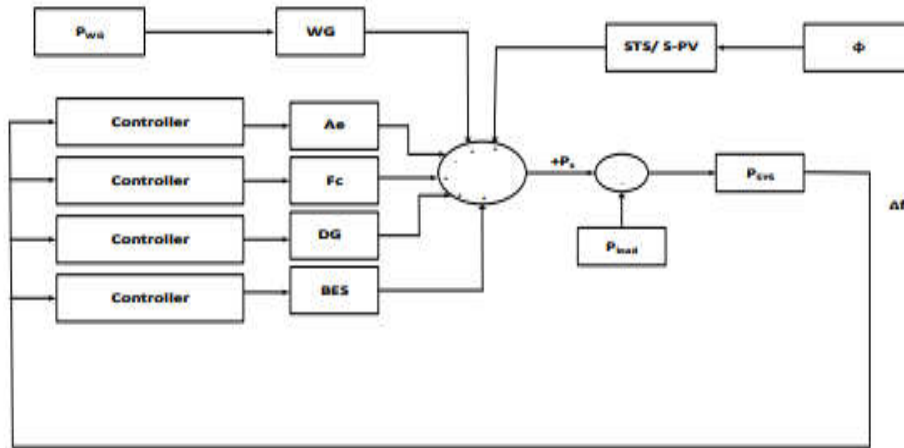

Fig.1 Block Diagram of Hybrid power system model

A. Wind Turbine Generator Model the Integrity of the Specifications

Wind is a naturally available fuel and can be used to produce clean and sustainable power. As the speed of the wind varies with time we cannot rely on the system directly as all the systems we use require constant power supply which can be achieved by speed regulation. The output depends on the wind speed at that instant. We can represent the higher order system into simplified first order lag as

$$G_{WG}(s) = \frac{K_{WG}}{T_{WG}s+1}$$

B. Solar Thermal Model

Solar energy is abundantly available in the nature in the form of light; this energy once harvested can deliver a reliable power to the system which is clean energy. In the recent trends solar and solar towers are two research topics in solar thermal power systems. This system can be effortlessly hybridized with other systems like wind, diesel, fuel cell, etc. solar power plants occupy larger areas in parabolic with collectors blending in unidirectional path for working fluid through pipes located at the focus of the parabola to heat. The exchange of power is in the form of steam, as the working fluid is heated to higher temperatures (393 OC). The reduced first order lag transfer function for the solar thermal power model as

$$G_{STS}(s) = \frac{K_{STS-S}}{T_{STS-S}s+1} * \frac{K_{STS-T}}{T_{STS-T}s+1}$$

C. Diesel Generator Model

Diesel generators are the mostly used generation systems off grid, the torque produced in the machine drives the synchronous generator machine producing the electrical output. In diesel system the output power directly depends on the rotor shaft speed which is inversely proportional to the load demand. With varying load demands the rotor dynamic response are effected, it is important that the prime mover has better and fast dynamic responses with good capabilities for disturbance rejection. The simplified first order transfer function for the Diesel system with time varying non linearity is given by

$$G_{DG}(s) = \frac{K_{DG}}{T_{DG}s+1}$$

D. Aqua Electrolyzer model

Aqua electrolyzers are mainly designed in the power system model to absorb the rapidly fluctuating output power from wind and solar thermal system, which generate the hydrogen required by the fuel cell system by electro conducting water and decomposing it into hydrogen and oxygen. The hydrogen generated is stored in a storage tank which is fuel for FC system. The transfer function model for the aqua electrolyzer can be expressed by

$$G_{Ae}(s) = \frac{K_{Ae}}{T_{Ae}s+1}$$

E. Fuel Cell model

The power generated in this system is through series of electro chemical reactions between hydrogen and oxygen. Fuel cell is used as a substitute to conventional generators, such as diesel generators, where the power produces is clean, sustainable, noise free and free from onsite pollutants. The output of a typical fuel cell is a DC voltage which should be converted to AC for grid

usage through semi-conductor devices such as dc/ac converters. The higher order function of the system consists of non-linearity, thus we consider a low order lag transfer function for analysing the low frequency domain model and is given as

$$G_{Fc}(s) = \frac{K_{Fc}}{T_{Fc}s+1}$$

F. Battery Energy Storage model

To maintain the grid for a short time period to regulate the fluctuation due to the non-conventional systems in the grid, we use the storage system. The fluctuations in the grid power even for a short time causes adverse effect of the load connected to the grid. These fluctuations can be regulated by providing an alternative solution which is possibly storage of wind energy. Battery energy storage systems are considered to be very advantageous due to their very good characteristics such as large energy density, fast access time, we can store large amount of wind energy. The transfer function model of the BESS model is represented in the first order form as

$$G_{BES}(s) = \frac{K_{BES}}{T_{BES}s+1}$$

III. PARTICLE SWARM OPTIMIZATION

In the recent years many soft computing were developed based on different animals and particles behaviours that are available in nature, which were proved to be effective in analysing and unravelling problems [9]. Particle Swarm Optimization (PSO) is one such novel population based technique, developed in 1995 by Dr. Russel Eberhard and collaborative behaviour of the flock of birds or fish schooling, when analysed PSO with evolutionary computation techniques such as Genetic Algorithm (GA) it shares many similarities. [10] The technique is better understood once we know the behaviour of birds when searching for food in an open environment. Unlike GA, PSO has no operator for evolution like cross over or mutation. In PSO the particles are known as potential solution, there fly through the problem space searching for the solution[11-12]. PSO simulates the behaviours of flock of birds searching for food.

The steps of the PSO PID controllers are summarized as follows:

Step 1: Create the initial population for initializing the optimization for parameters (Kp, Ki, Kd). Each parameter in the problem area is a particle thus the velocity and position represents the solution to the problem.

Step 2: The objective function considered here for minimizing frequency deviations is integral square error (ISE), we calculate the J values using mat lab model.

Step 3: Evaluation of the fitness function. The degree of fitness is evaluated based in the criterion. Since PSO is a minimization function, the objective function is the fitness function.

Step 4: Generating the P best and G best values for the initial iteration the values are updated for the next iterations and the final values for updating the velocity and position.

Step 5: Replace the present population with a new set of population.

Step 6: On reaching the final criterion terminate; else go to step 2.

In PID controller design method, the most common objective function is integral absolute error (IAE), integral of time weight square error (ITSE), integral square error (ISE), etc. here in this model we have considered Integral Square Error (ISE) as our objective function to reduce the frequency deviations.

$$J = \int_0^{\infty} (\Delta f)^2 dt.$$

Minimize J
 Subjected to
 $K_p^{\min} < k_p < k_p^{\max}$
 $K_i^{\min} < k_i < k_i^{\max}$
 $K_d^{\min} < k_d < k_d^{\max}$

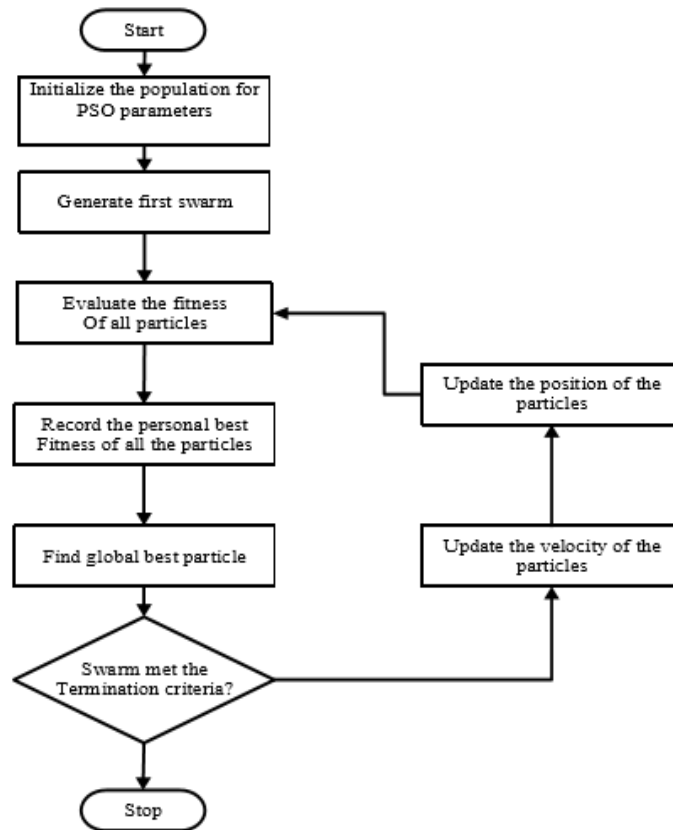

Fig 2. Flowchart representing PSO algorithm.

IV. RESULTS AND DISCUSSIONS

In this module, dynamic performance of the proposed hybrid model is analysed for simulations in time domain. By defining various operating points and disturbance conditions are presented with optimum gain settings of conventional, GA and PSO based PI and PID controllers respectively. The conventional optimization approach we considered here is ISE criterion where only one parameter is varied at a time keeping rest all parameters the same, for one complete iteration .we have considered the following two cases, as shown in table 2 are considered for case studies.

A. Case 1: Time Domain Analysis

In this case study, we consider the below conditions for wind, solar and load analysis, during $0 \leq t \leq 40s$, the average wind power and solar irradiation power is kept 0.5PU and 0.36PU respectively after 40s, wind and solar power are suddenly reduced down to 0.36PU and 0.18PU respectively. Load demand during $0 \leq t \leq 80s$ is maintained at 1PU, after 80s the load demand suddenly elevates to 1.1PU. The deviation in the load demand to the generation is attuned by the Fuel cell, diesel, BES through controllers since generation from solar and wind is constant. Total power generated can be expressed by

$$P_s = P_{WG} + P_{STS} - P_{Ae} + P_{FC} + P_{DG} + P_{BES}$$

Due to the sudden variations in the load demand, and variations in power outputs of solar and wind systems, there is a fluctuation in the system frequency at power level. This deviation in the power frequency is controlled by the controllers (PI/PID) adjusting the system outputs automatically such that the error in the frequency deviation is minimized.

The system gains for the controllers are to be calculated through computational intelligence and conventional controllers, the gains of the conventional and GA based controller are calculated in and are directly considered for the hybrid system. The new gain values are calculated using PSO optimization technique, we observed that the performance of the PID controller is best amongst PI and PID controllers for both conventional and GA, for studies in terms of peak transient deviation, settling time and steady state.

B. Case 2: Time Domain Analysis

In this case study, we consider the below conditions for wind, solar and load analysis, during $0 \leq t \leq 40s$, the average wind power and solar irradiation power is kept 0.5PU and 0.36PU respectively after 40s, wind and solar power are suddenly reduced down to 0.36PU and 0.18PU respectively. Load demand during $0 \leq t \leq 80s$ is maintained at 1PU, after 80s the load demand suddenly elevates to 1.1PU. The deviation in the load demand to the generation is attuned by the Fuel cell, diesel, BES through controllers since generation from solar and wind is constant. Total power generated can be expressed by

$$P_s = P_{WG} + P_{STS} - P_{Ae} + P_{Fc} + P_{DG} + P_{BES}$$

Due to the sudden variations in the load demand, and variations in power outputs of solar and wind systems, there is a fluctuation in the system frequency at power level. This deviation in the power frequency is controlled by the controllers (PI/PID) adjusting the system outputs automatically such that the error in the frequency deviation is minimized. In this case we have considered a solar PV system instead of solar thermal system, where the remaining conditions remain the same for both the models.

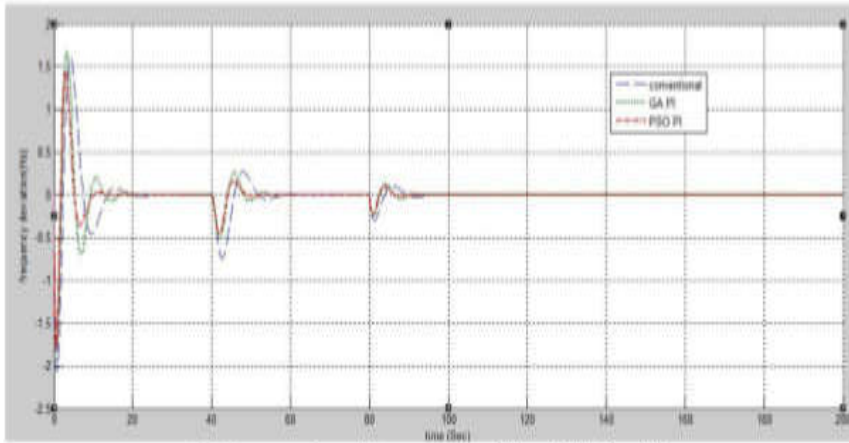

Fig 3: output of case 1 for conventional GA and PSO based PI

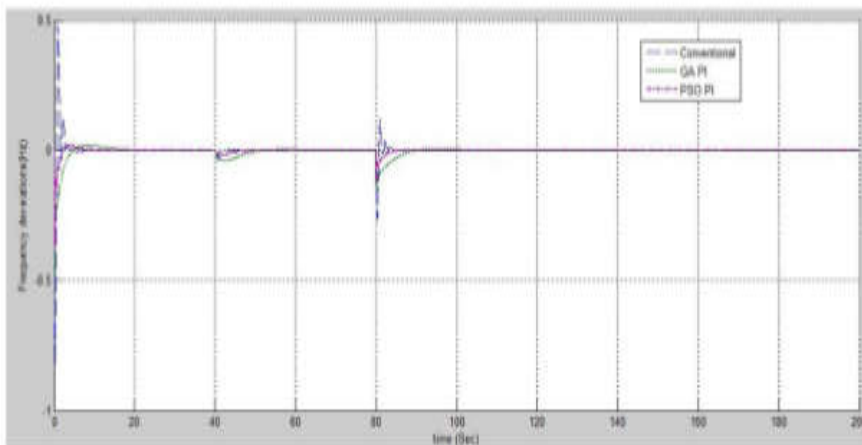

Fig 4: output of case 2 for conventional GA and PSO based PI

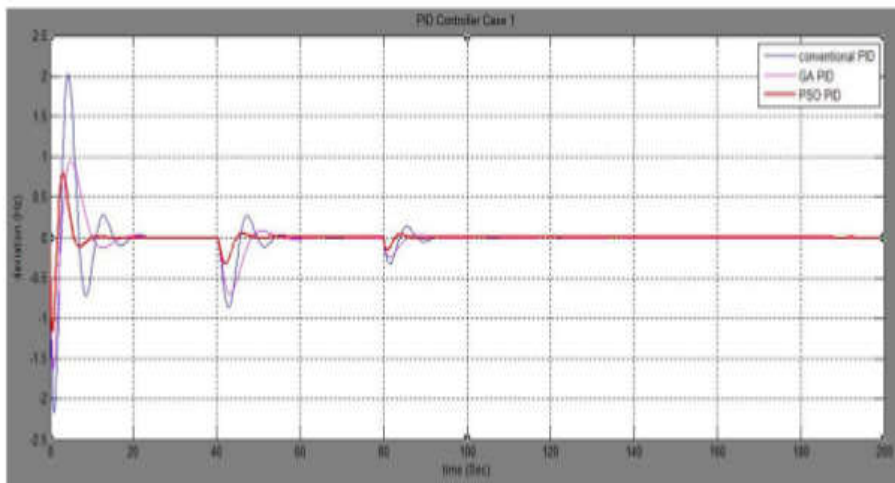

Fig 5: output of case 1 for conventional GA and PSO based PID

The system gains for the controllers are to be calculated through computational intelligence and conventional controllers, the gains of the conventional and GA based controller are calculated in [16] and are directly considered for the hybrid system. The

new gain values are calculated using PSO optimization technique, we observed that the performance of the PID controller is best amongst PI and PID controllers for both conventional and GA, for studies in terms of peak transient deviation, settling time and steady state.

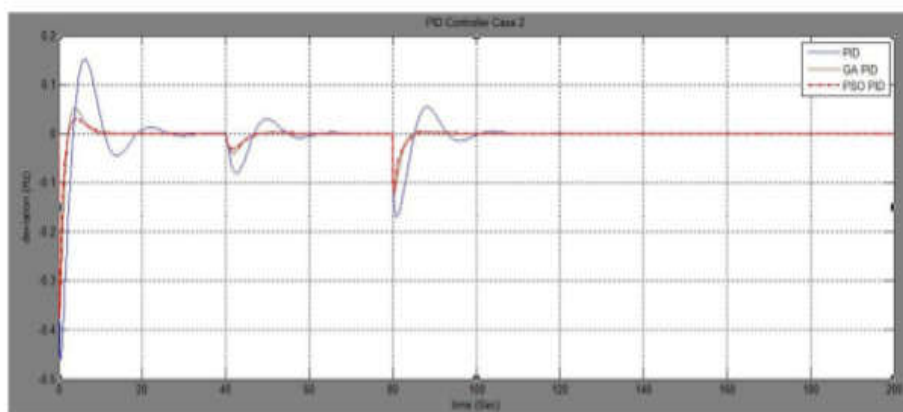

Fig 6: output of case 2 for conventional GA and PSO based PID

V. CONCLUSION

To uphold the stability in the system, the frequency deviations in the system are to be delimited to the nominal values. This work is done by an automatic generation control system which can eliminate the disparity in supply and demand under fluctuating power conditions in load and generation. In this paper, we have presented an autonomous hybrid model consisting of Wind turbine generator (WG), solar photovoltaic (S-PV), diesel generator(DG), fuel cell(FC), battery energy storage system (BES), solar thermal power system(STPS) and aqua electrolyser (AE) . Fuel cell input is attained from the aqua electrolyser system which generates hydrogen which is energy for fuel cell. The models for the above generation and storage systems are selected to simulate the significant performance of projected hybrid system. In order to maintain stability i.e., to reduce the frequency deviations due to mismatch in power because of abrupt variations in generation and load, a controller is to be designed to regulate the output power from deviating (PI/PID). Conventional methods were used to calculate the gains and verify the performance of the controllers, along with these computational techniques such as GA and PSO were also applied. Analysing the dynamic behaviour of each controller in time – domain performance of each controller is observed in isolated operating modes. On observing the responses PID is more dependable amongst PI and PID controller which are evaluated based on the study in terms of deviations due to peak transients and settling time. Further, it is observed that the gains of the controllers calculated through Computational techniques were performing as better controllers than their counterparts. However, in all the cases, the PSO based PID controller achieved better results than the conventional and the GA based controllers. From the simulation results, it is witnessed that PSO based technique is more reliable for automatic generation control.

REFERENCES

- [1] Senjyu T, Nakaji T, Uezato K, Funabashi T. A hybrid power system using alternative energy facilities in isolated islands. *IEEE Trans Energy Convers* 2005;20(2):406–14.
- [2] Kumar BS, Mishra S, Senroy N. Agc for distributed generation. *Proc Int Conf Sustain Energy Technol* 2008:89–94
- [3] Hajizadeh Amin, Aliakbar Golkar Masoud. Control of hybrid fuel cell/energy storage distributed generation system against voltage sag. *Int J Electr Power Energy Syst* 2010;32(5):488–97
- [4] Cetin Elmas, Tuncay Yigit. Genetic Algorithm based on-line tuning of a PI controller for a switched reluctance motor drive. *Electr Power Comp Syst* 2007;35(6):675–91
- [5] Kurohane K, Senjyu T, Toshihisa Yona A, Urasaki N, Goya T, Funabashi T. A hybrid smart AC/DC power system. *IEEE Trans Smart Grid* 2010;1(2):199–204
- [6] Karr C, Gentry E. Fuzzy control of ph using genetic algorithms. *IEEE Trans Fuzzy Syst* 1993;1(1):46–53.
- [7] Kim Jin-Sung, Kim Jin-Hwan, Park Ji-Mo, Park Sung-Man, Choe Won-Yong, Heo Hoon. Auto tuning PID controller based on improved genetic algorithm for reverse osmosis plant. *Int J Intell Syst Technol* 2008;3(4).
- [8] Lee Dong-Jing, Wang Li. Small-signal stability analysis of an autonomous hybrid renewable energy power generation/ energy storage system – Part I: timedomain simulations. *IEEE Trans Energy Convers* 2008;23(1):311–20
- [9] Krohling RA, Rey JP. Design of optimal disturbance rejection PID controllers using genetic algorithms. *IEEE Trans Evol Comput* 2001;5:78–82.
- [10] Fleming PJ, Purshouse RC. Evolutionary algorithms in control system engineering: a survey. *Control Eng Pract* 2002;10:1223–41
- [11] Wang C, Nehrir MH. Power management of a stand-alone wind/photovoltaic/ fuel cell energy system. *IEEE Trans Energy Convers* 2008;23(3):957–67.
- [12] Sedaghat B, Jalilvand A, Noroozian R. Design of a multilevel control strategy for integration of stand-alone wind/diesel system. *Int J Electr Power Energy Syst* 2012;35(1):123–37. [G. Eason, B. Noble, and I. N. Sneddon, “On certain integrals of Lipschitz-Hankel type involving products of Bessel functions,” *Phil. Trans. Roy. Soc. London*, vol. A247, pp. 529–551, April 1955. (*references*)